

Product Information

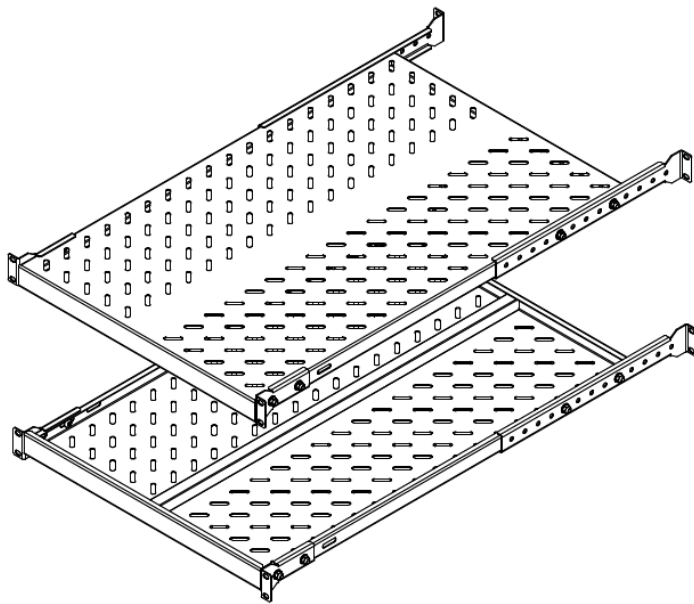

Features

- Adjustable Depth for installation
- 700 and 800 mm deep
- 90 kg load rate
- RoHS compliance
- Conforms to ASTM D610-01 and ASTM B117 (500 hours salt spray test)

Materials/Finish

- High grade cold rolled steel 2.00 mm thickness.
- Powder coat finish preceded by 5 stage iron phosphate pretreatment.
- Standard color is low gloss black.

Part Code	Description	Min "A"	Min "B"	Max "C"
SVF700NBLK	19" Shelf Vented Fixed 700 Deep Black	641	700	909
SVF800NBLK	19" Shelf Vented Fixed 800 Deep Black	741	800	1009

Dimensions

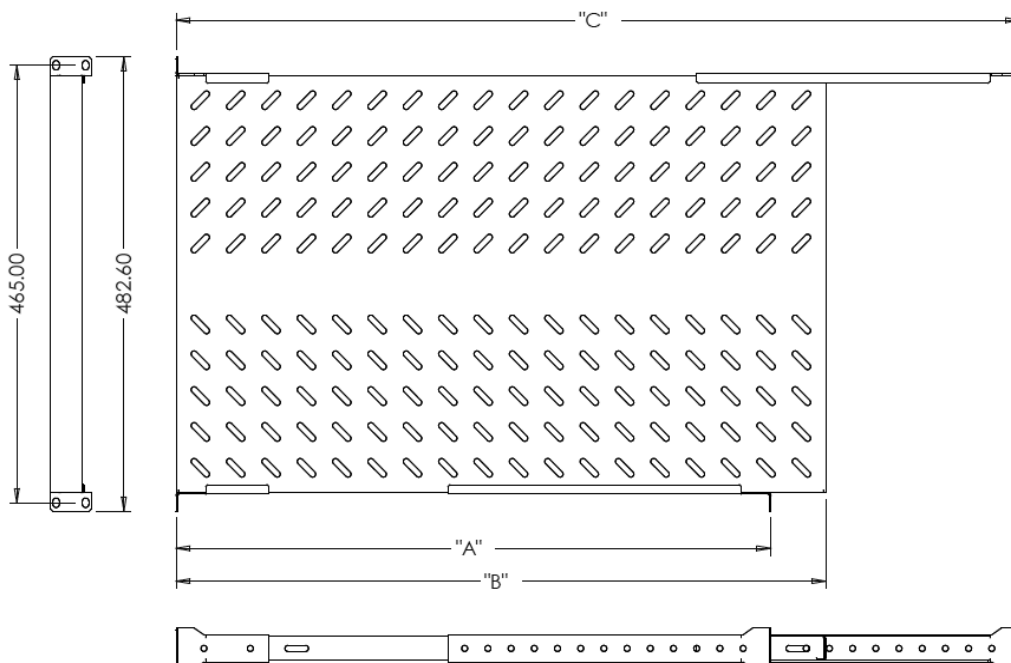

Cheval Electronic Enclosure Co., Ltd.

International Contact : Tel : +66 (0) 2315 1504
 Thailand Contact : Tel : +66 (0) 2744 1632

Fax : +66 (0) 2315 1506
 Fax : +66 (0) 2399 1783

E-mail : commce@chevalgrp.com
 E-mail : domestic_sales@chevalgrp.com

Product Information

Part List

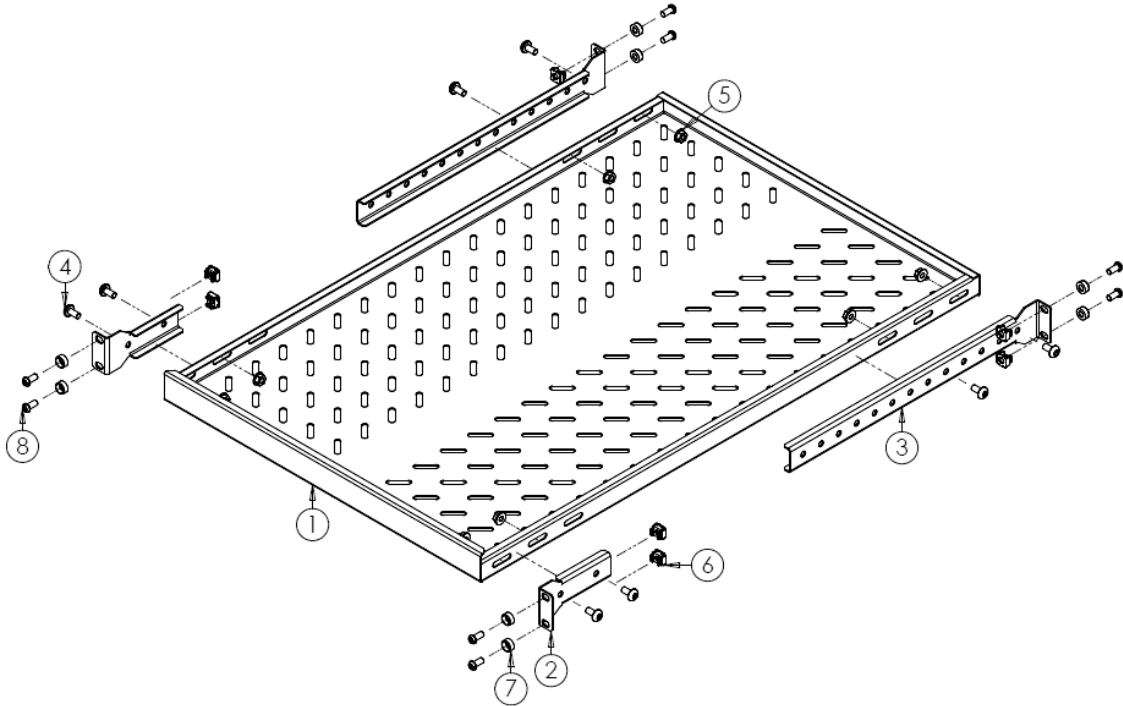

Description	Quantity
1. 19"Adjustable vented shelf	1 piece
2. Front mounting Bracket	2 pieces
3. Rear mounting Bracket	2 pieces
4. Screw T-30 M6x12	8 pieces
5. Hex Flange Nut M6	8 pieces
6. Cage Nut M6	8 pieces
7. Plastic Cup washer M6	8 pieces
8. Phillips M6x16 pan Screw	8 pieces

Installation

1. Install front and rear mounting bracket on left and right side of 19" Adjustable Vented Shelf with two M6x12 T-30 screw and hex flange nut on each side. Align front side of shelf and mounting bracket to be in same plane then tighten all screw with torque 40-50 inch lbs.

2. Adjust distance between front and rear mounting bracket to fit to the front and rear vertical mounting channel. See first image below.

3. Install 8 M6 cage nut on front and rear vertical mounting channel. See balloon A, B.

Note : Eight cage nuts at front and rear vertical mounting channel shall be installed on the upper and lower hole in the same U number.

4. Hold the shelf and rotate clockwise about 30-45 degree [See balloon number 1] then move it inside the Arion rack. See balloon number 2.

5. Rotate shelf counter clockwise until top surface is in horizontal level. See balloon number 3.

Cheval Electronic Enclosure Co., Ltd.

International Contact : Tel : +66 (0) 2315 1504
Thailand Contact : Tel : +66 (0) 2744 1632

Fax : +66 (0) 2315 1506
Fax : +66 (0) 2399 1783

E-mail : commce@chevalgrp.com
E-mail : domestic_sales@chevalgrp.com

19" Adjustable Vented Shelves



ISO 9001 & ISO 14001 Certified

Product Information

6. The rear side of front mounting bracket should touch the front side of vertical mounting channel.

Note : Now the rear mounting bracket will stay outside the rear vertical mounting channel

7. Fix shelf to Vertical mounting channel with Phillips M6x16 and plastic washer to 8 cage nut on the rear side of Vertical mounting channel with torque 40-50 inch lbs. See balloon number 4 and 5

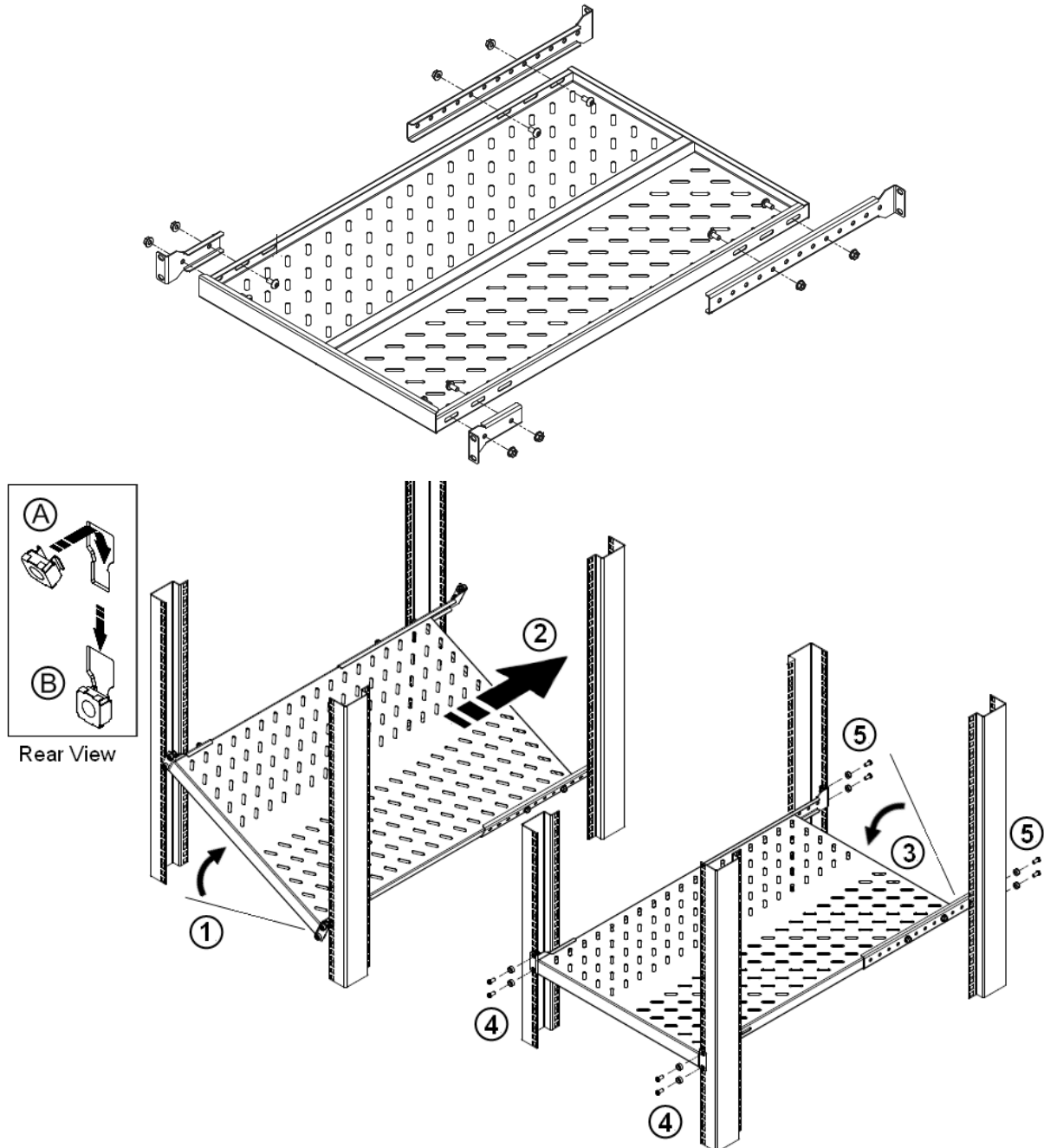

Note : Torque 40-50 inch lbs

Cheval Electronic Enclosure Co., Ltd.

International Contact : Tel : +66 (0) 2315 1504
Thailand Contact : Tel : +66 (0) 2744 1632

Fax : +66 (0) 2315 1506
Fax : +66 (0) 2399 1783

E-mail : commce@chevalgrp.com
E-mail : domestic_sales@chevalgrp.com