

Arion: 19" Rack



ISO 9001 & ISO 14001 Certified

Product Information

Arion rack 800W series: Vendor neutral and highly versatile 19" rack provides quality solutions for a wide variety of IT and Data Center applications .

Features

- High quality cost effective solution.
- Minimum 800 kg static load rated for basic rack.
- Contoured high density perforated door exceeds major IT equipment air flow requirements.
- Provides extensive work space for cable management.
- Light weight and strong .
- Split level side panels provide convenient access to installed equipment .
- Depth adjustable 19" vertical mounting rails in 6.35 mm increments .
- "U" numbers printed on 19" rails.
- Knock down design for efficient shipping.
- Quick assembly time, approximately 25 minutes.
- Quick release, field reversible doors.
- Flexible packing methods allows convenient stocking and end user delivery.
- Multiple sizes available.
- Customization requests welcome.



Patents Pending : 1002000994, 1001000784, 1001000785, 1001000786, 1001000787

Cheval Electronic Enclosure Company, Limited

145 Bangplee Industrial Estate Soi 4 Moo 17 Bangsaotong Samutprakarn 10540 Thailand
Tel: +66 2315 1504-5,+66 2315 2263-5 Fax: +66 2 315 1506,+66 2705 1006 www.chevalgrp.com

Arion: 19" Rack



ISO 9001 & ISO 14001 Certified

Product Information

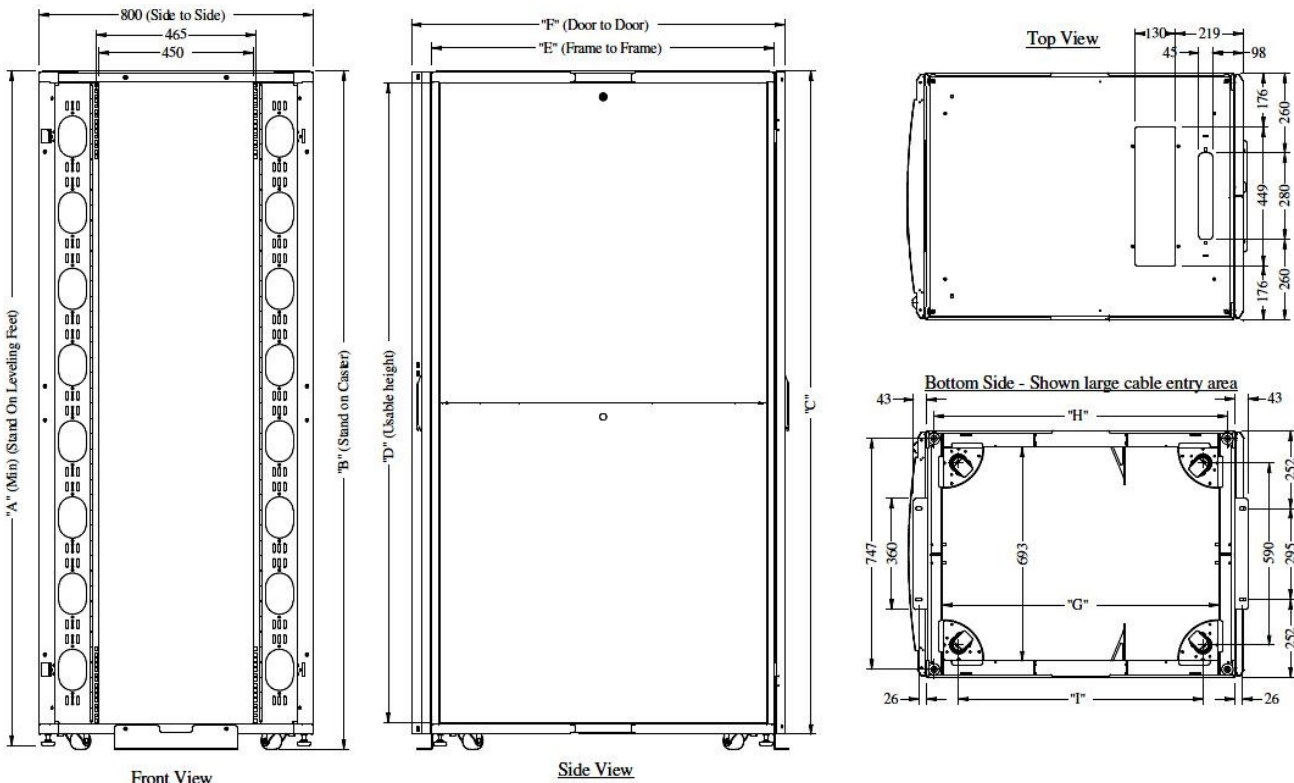

| Dimensions (Unit:MM) | | | | |
|----------------------|---------|---------|---------|---------|
| DIM "E" | DIM "F" | DIM "G" | DIM "H" | DIM "I" |
| 1000 | 1090 | 897 | 952 | 793 |
| 1200 | 1290 | 1097 | 1152 | 993 |

| Dimensions (Unit:MM) | | | | |
|----------------------|---------|---------|---------|---------|
| UNIT HEIGHT | DIM "A" | DIM "B" | DIM "C" | DIM "D" |
| 42U | 1968 | 1981 | 1936 | 1865 |
| 45U | 2101 | 2114 | 2070 | 1999 |
| 47U | 2190 | 2203 | 2158 | 2087 |

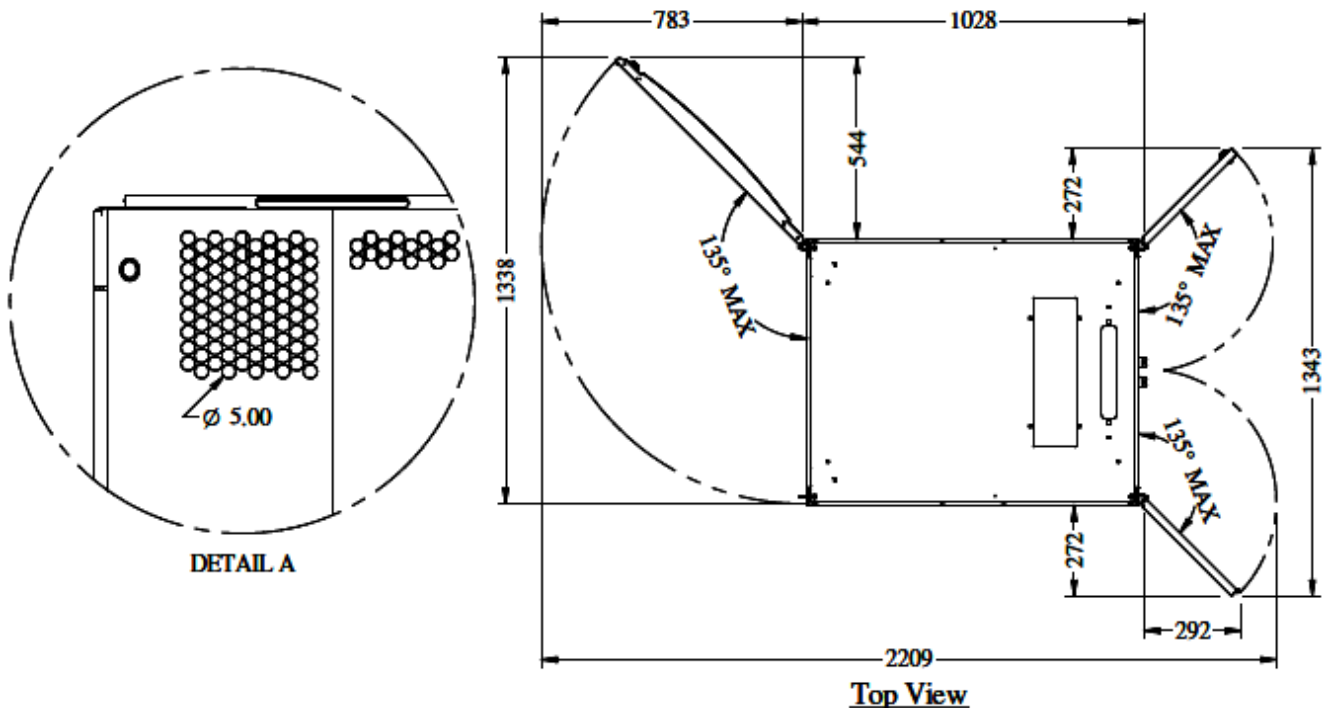

Cheval Electronic Enclosure Company, Limited

145 Bangplee Industrial Estate Soi 4 Moo 17 Bangsaotong Samutprakarn 10540 Thailand
 Tel: +66 2315 1504-5,+66 2315 2263-5 Fax: +66 2 315 1506,+66 2705 1006 www.chevalgrp.com

Arion: 19" Rack



ISO 9001 & ISO 14001 Certified

Product Information

Standards and Materials

- Dimensions conform to EIA-310E, IEC-60297-2 .
- Five stage iron-phosphate pretreatment with textured powder coat finish, tested to 500 hours salt spray under ASTM-D610-01 and ASTM-B117
- Standard color is low gloss textured black.
- Premium grade Hot and Cold rolled steel sheet.
- Designed and Manufactured under ISO 9001:2008 and ISO 14001.
- All materials RoHS compliant.

Technical Specifications

| Rack Model | 1000 deep | | | 1200 deep | | |
|--|-----------|-------|-------|-----------|-------|-------|
| | 42U | 45U | 47U | 42U | 45U | 47U |
| Overall Height of Rack without Casters | 1936 | 2070 | 2158 | 1936 | 2070 | 2158 |
| Overall Height of Rack including Casters | 1981 | 2114 | 2203 | 1981 | 2114 | 2203 |
| Usable Rack Height | 42U | 45U | 47U | 42U | 45U | 47U |
| Net weight Kg. (include middle side brace and caster kits) | 114.4 | 117.6 | 122 | 117.4 | 121 | 124.6 |
| Maximum Mounting Depth (mm) | 895 | 895 | 895 | 1095 | 1095 | 1095 |
| Front Door Total Open Area (sq in) | 1483 | 1580 | 1652 | 1483 | 1580 | 1652 |
| Rear Door Total Open Area (sq in) | 1563 | 1668 | 1741 | 1563 | 1668 | 1741 |
| Door opening radius | 135 ° | 135 ° | 135 ° | 135 ° | 135 ° | 135 ° |

Cheval Electronic Enclosure Company, Limited

145 Bangplee Industrial Estate Soi 4 Moo 17 Bangsaotong Samutprakarn 10540 Thailand
Tel: +66 2315 1504-5,+66 2315 2263-5 Fax: +66 2 315 1506,+66 2705 1006 www.chevalgrp.com