

Product Information

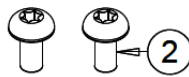
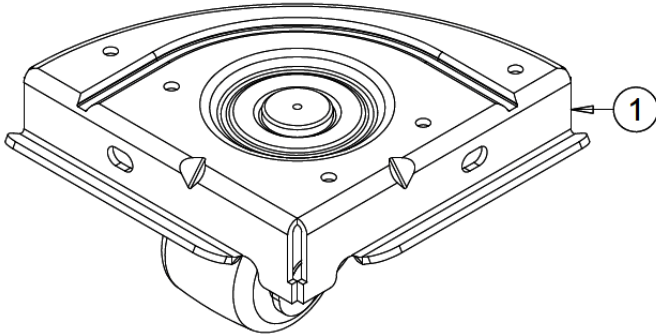

Features

- Load rate up to 275 kg per caster
- Mounts direct to bottom frame
- 360 degree swivel
- RoHS compliance
- Conforms to ASTM D610-01 and ASTM B117 (500 hours salt spray test)

Materials/Finish

- High grade cold rolled steel 3.0 mm thickness.
- Powder coat finish preceded by 5 stage iron phosphate pretreatment.
- Standard color is low gloss black.

Part Code	Description
CAS2P	Arion caster kit (set of 4)

Dimensions

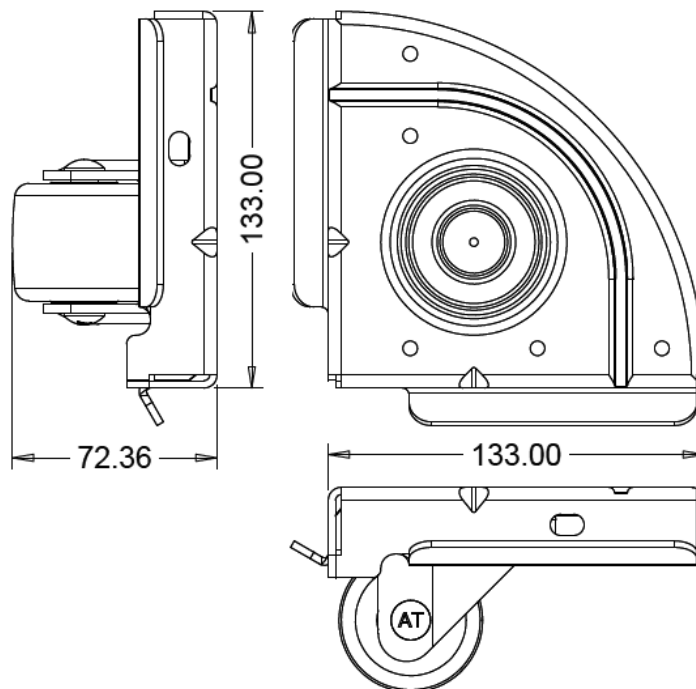

Part List

Description	Quantity
1. Caster	4 pieces
2. T-30 Screw M6x12	8 pieces

Installation

Cheval Electronic Enclosure Co., Ltd.

Casters Kit for Arion rack

Product Information

1. Remove all Side Panel , front and rear door from Arion rack.
2. Lay down Arion rack to floor.
3. Install four casters at four corner of Arion rack.
4. Fix caster to Frame bottom with Hex screw M6 two pieces on each caster.
5. Tighten with torque 75-90 inch lbs.

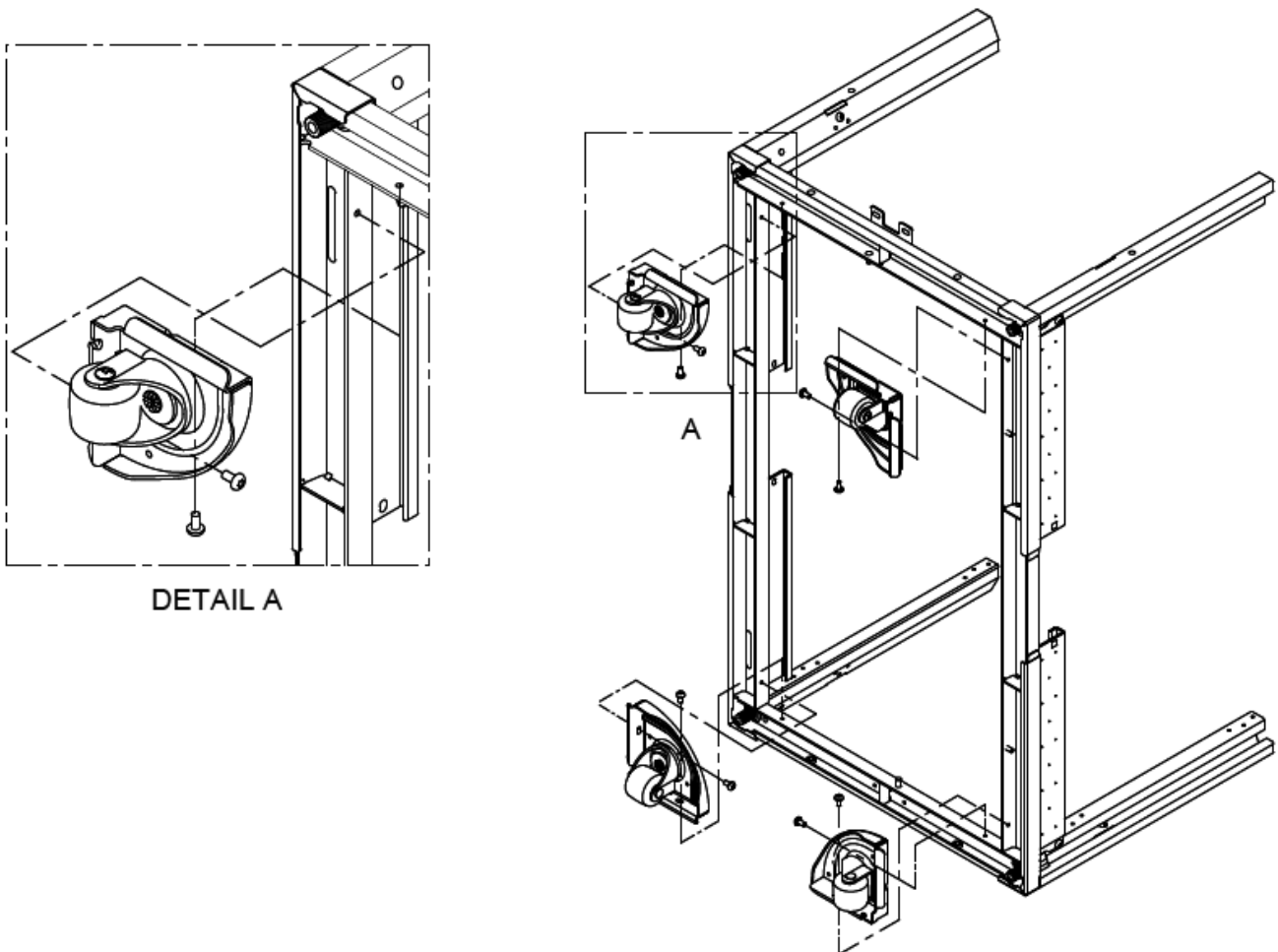

Note : Torque 75-90 in lbs

Cheval Electronic Enclosure Co., Ltd.

International Contact : Tel : +66 (0) 2315 1504
Thailand Contact : Tel : +66 (0) 2744 1632

Fax : +66 (0) 2315 1506
Fax : +66 (0) 2399 1783

E-mail : commce@chevalgrp.com
E-mail : domestic_sales@chevalgrp.com