

Light Equipment Shelves 2U-3U

Product Information

These shelves mount directly to the front of the 19" vertical rails and can support loads upto 10 kg. Ideal for smaller non-rack mountable devices .

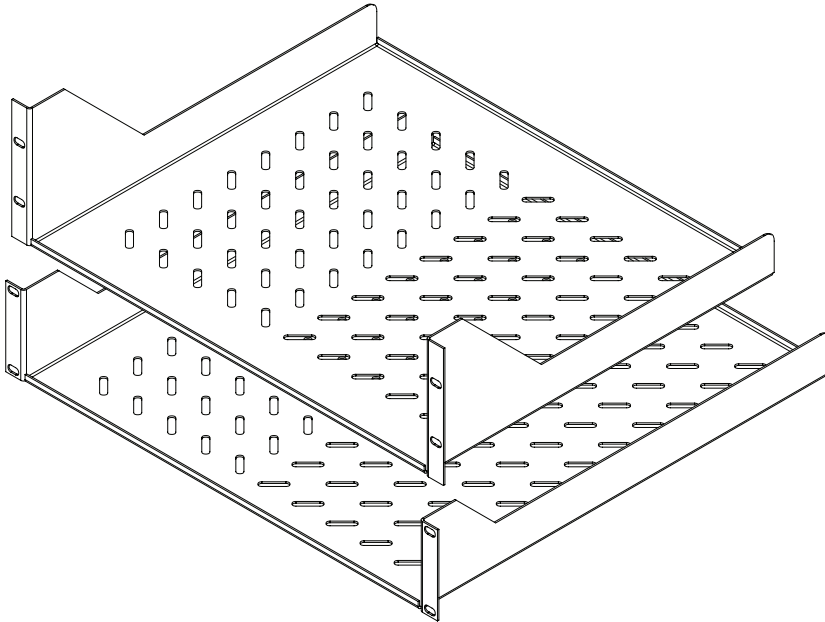

Features

- EIA-310E 19" Standard
- Easy to install to the front of the 19" vertical rails
- RoHS compliant

Material / Finish

- High grade cold rolled steel 1.2mm thickness
- Powder coat finish preceded by 5 stage iron phosphate pretreatment
- Standard color is low gloss black
Special colors upon request .

Dimensions*

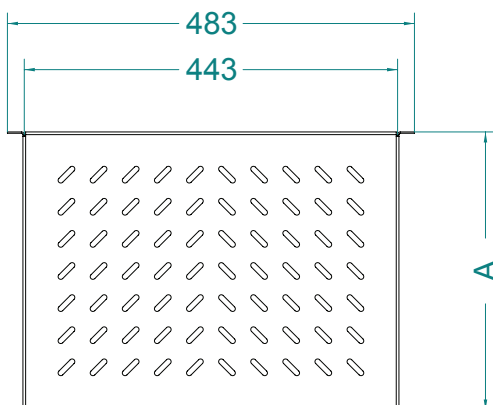
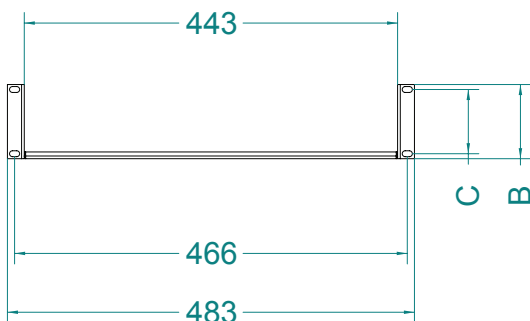

Unit Ref.	B	C
2U	88	76
3U	133	52

Item	Part Number	Part Name	A	Rated Load (Kg)
1	SL3302UBLK	Light Equipment Shelf 330 2U	330	10
2	SL3902UBLK	Light Equipment Shelf 390 2U	390	10
3	SL4602UBLK	Light Equipment Shelf 460 2U	460	10
4	SL3903UBLK	Light Equipment Shelf 390 3U	390	10

*Dimensions are in millimeter

Cheval Group of Companies

Light Equipment Shelves 2U-3U

Product Information

Application and Installation :

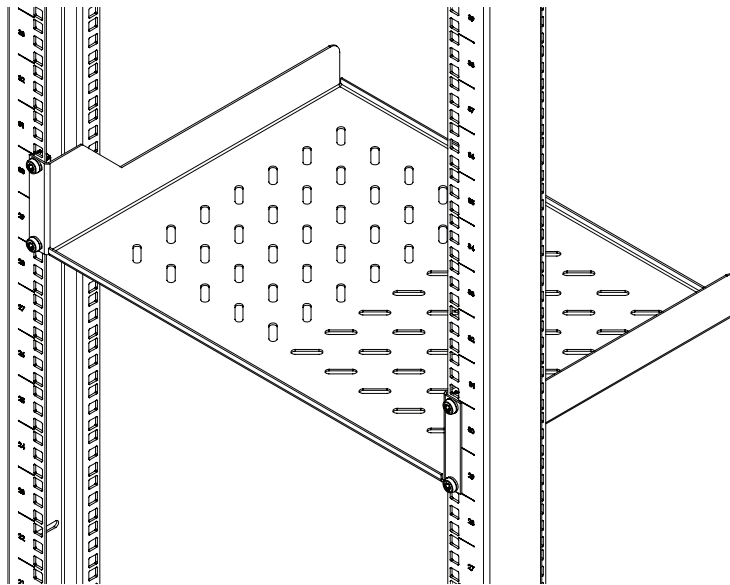
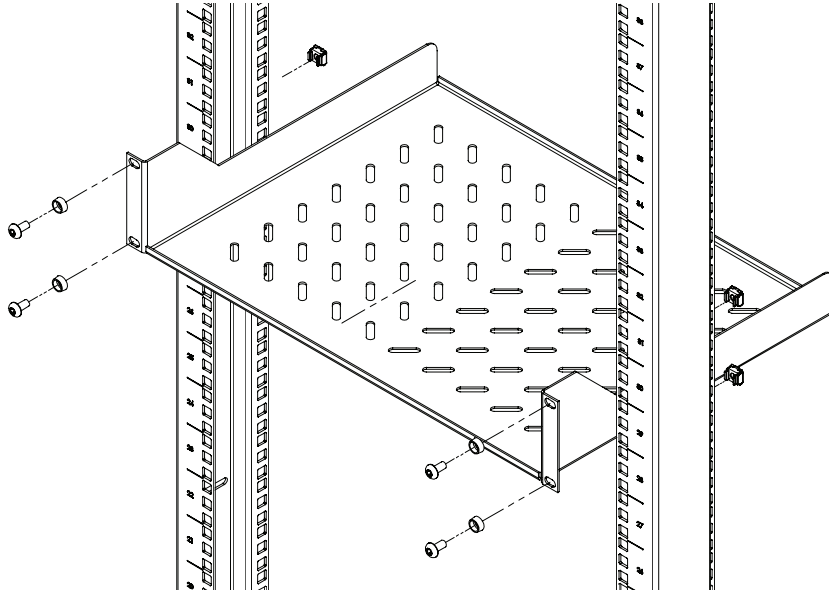

Contents of KIT :

Item	Part Name	Qty
1	Light Equipment Shelf	1
2	Washer M6 Black (Plastic Cup)	4
3	Hex Socket Cap Screw M6-12	4
4	Caged Nut M6 14-16 SWG	4

Cheval Group of Companies